

CAD FILE:

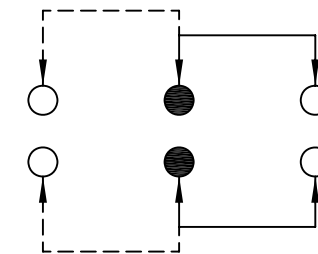

SCHEMATIC (NON-SHORTING)

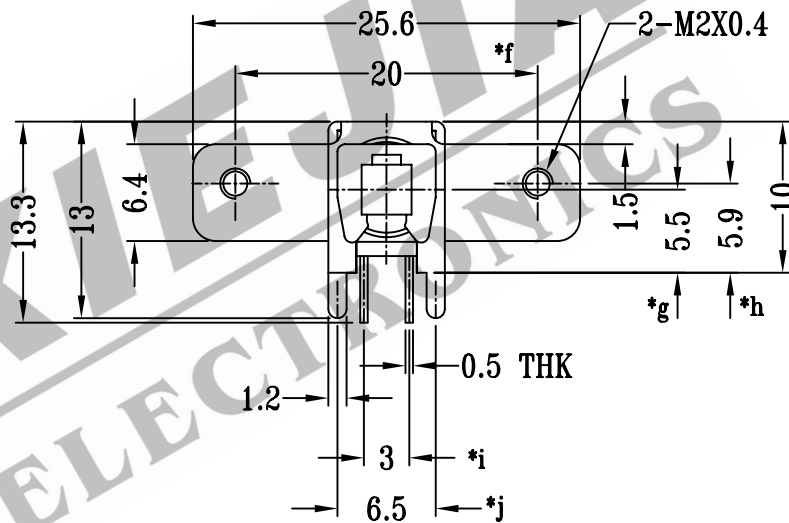
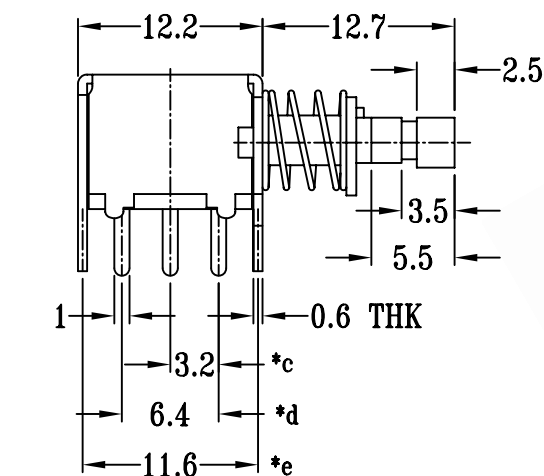
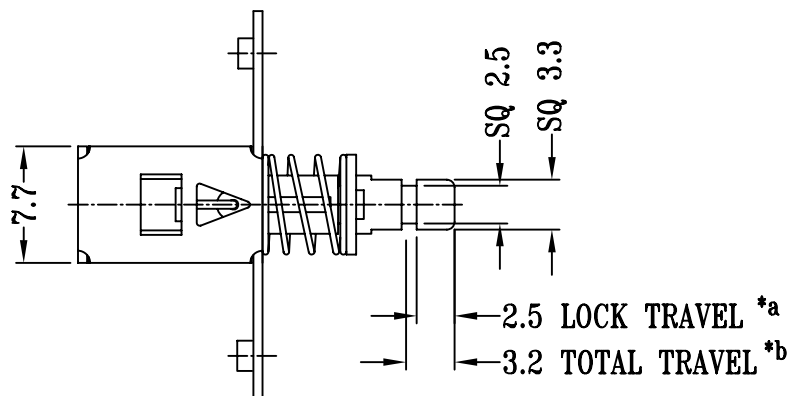
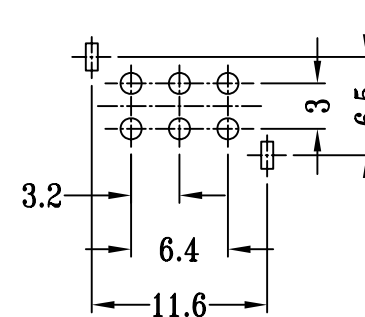

P.C.B LAYOUT

注:带"*"表示关键尺寸(10个)

9	CONTACT CLIP	PBS STRIP	2	Ag PLATED	TOLERANCE UNLESS SPECIFIED	SHENZHEN XIEJIA ELECTRONICS CO.,LTD.				
8	TERMINAL	BRASS STRIP	6	Ag PLATED OVER Ni PLATED						
7	BASE	PHENOLIC RESIN	1	NATURAL	WITHIN: 1.5±0.1mm OVER: 1.5±0.2mm	ISSUE	DATE	DESCRIPTIONS OF REVISION		APPD.
6	FRAME	STEEL STRIP	1	Ni PLATED		TITLE : PUSH SWITCH		UNIT : mm	DRWG NO.: XJ-DR-PS22F49-00	
5	SPRING PLATE	PBS STRIP	1	NATURAL	MODEL: PS-22F49 (LOCKED)		SCALE: 2 : 1	DWN.	ZHOUYU	2004-9-18
4	LOCK NEEDLE	PBS WIRE	1	NATURAL	ALL MATERIALS MUST BE COMPLIANT TO ROHS		CHK'D		FANGYING	2004-9-18
3	SPRING	STEEL WIRE	1	Ni PLATED			APPD.		KANGXINAN	2004-9-18
2	BLOCK	STEEL STRIP	1	Ni PLATED						
1	KNOB	POM	1	BLACK						
NO.	PARTS	MATERIALS	Q'TY	FINISH						